



US 20110090202A1

(19) **United States**

(12) **Patent Application Publication**
Han

(10) **Pub. No.: US 2011/0090202 A1**

(43) **Pub. Date: Apr. 21, 2011**

(54) **PIXEL AND ORGANIC LIGHT EMITTING DISPLAY USING THE SAME**

(30) **Foreign Application Priority Data**

Oct. 19, 2009 (KR) 10-2009-0099213

(75) Inventor: **Sam-II Han, Yongin-city (KR)**

Publication Classification

(73) Assignee: **Samsung Mobile Display Co., Ltd., Yongin-city (KR)**

(51) **Int. Cl.**
G09G 3/30 (2006.01)
G09G 5/00 (2006.01)

(52) **U.S. Cl.** **345/211; 345/76**

(21) Appl. No.: **12/852,344**

(57) **ABSTRACT**

(22) Filed: **Aug. 6, 2010**

A pixel circuit for an organic light emitting diode display is disclosed. The pixel is configured to provide fast response time and good isolation from data transition coupling.

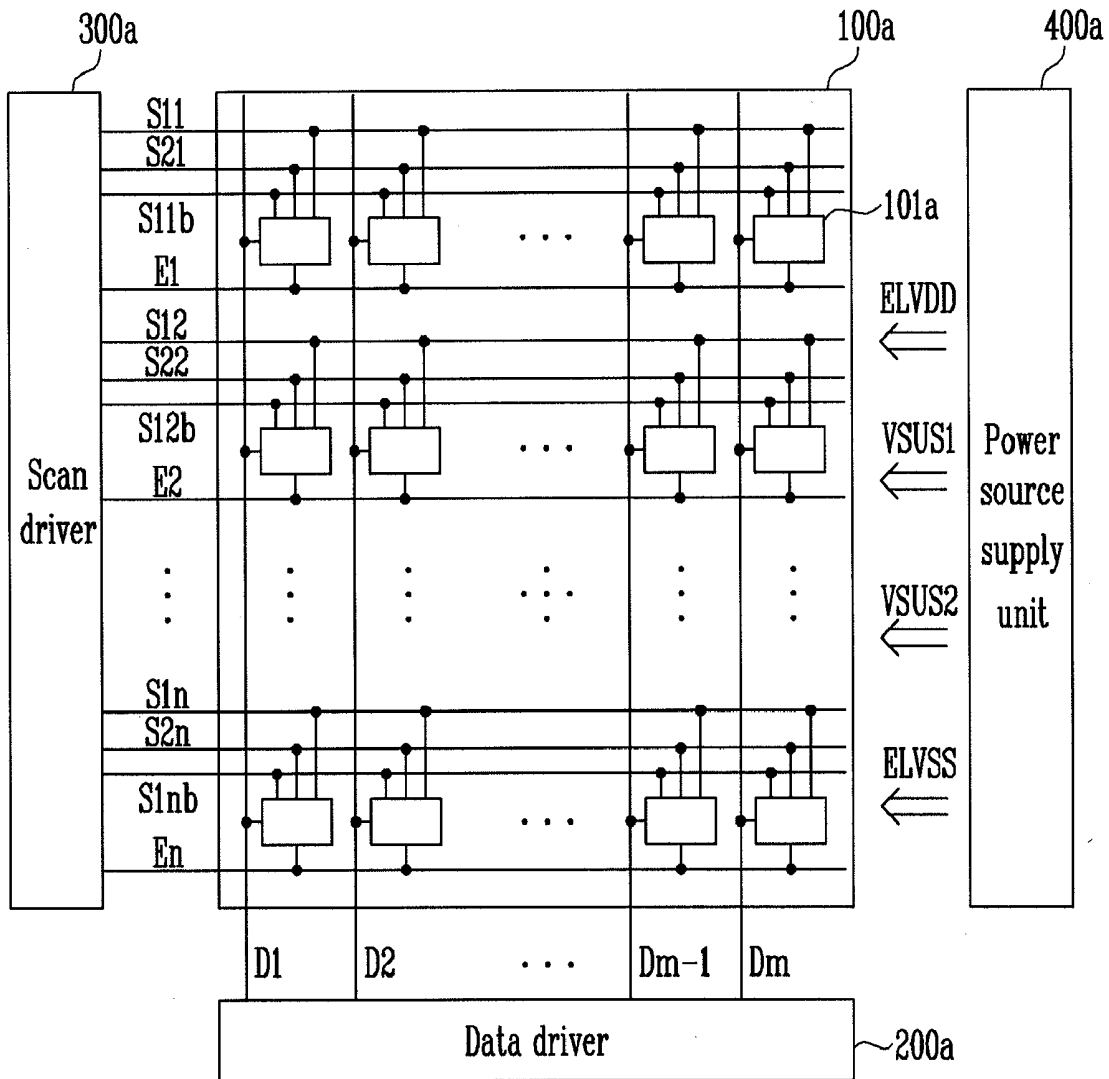

FIG. 1

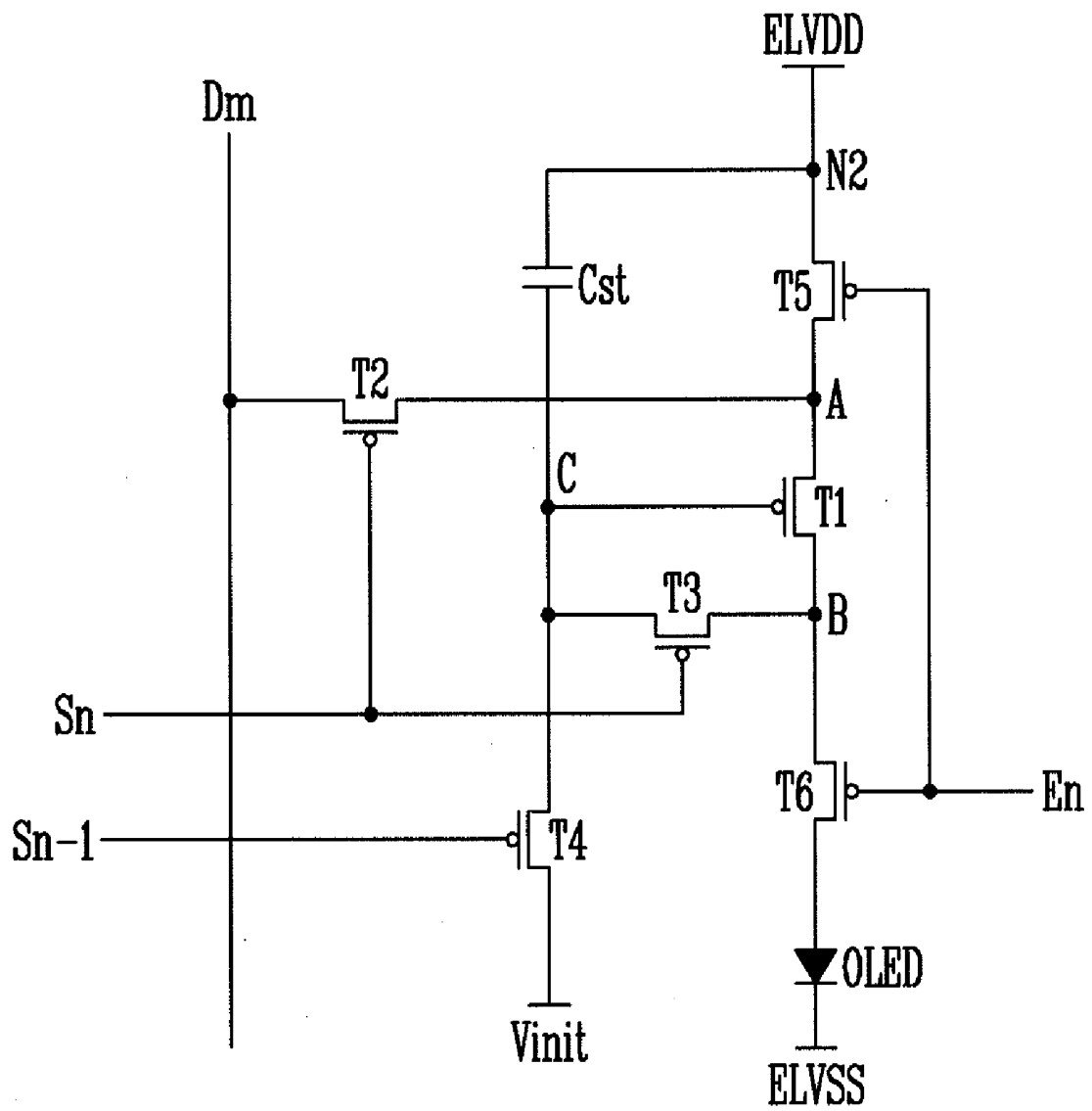

FIG. 2

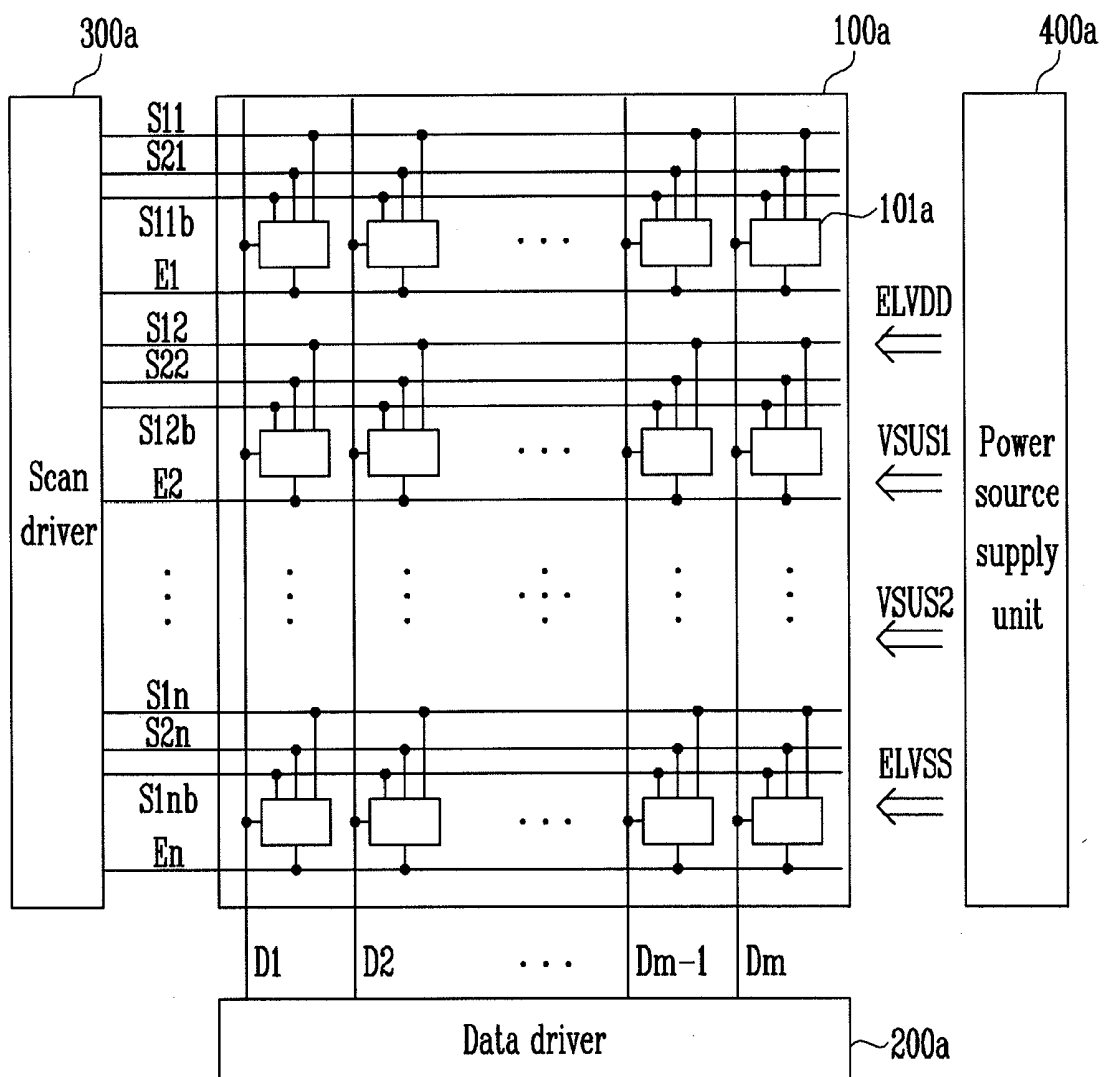

FIG. 3

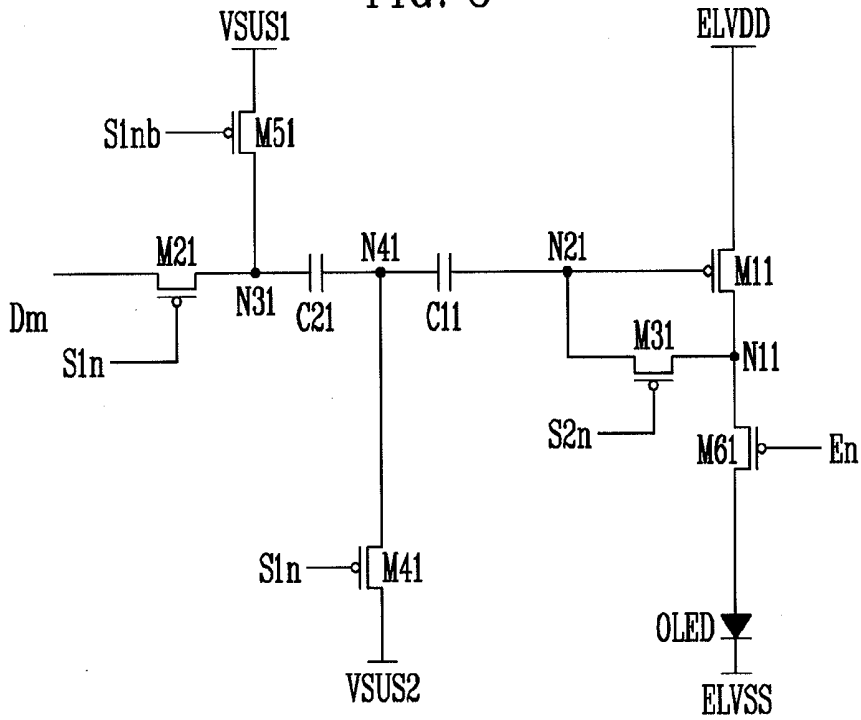

FIG. 4

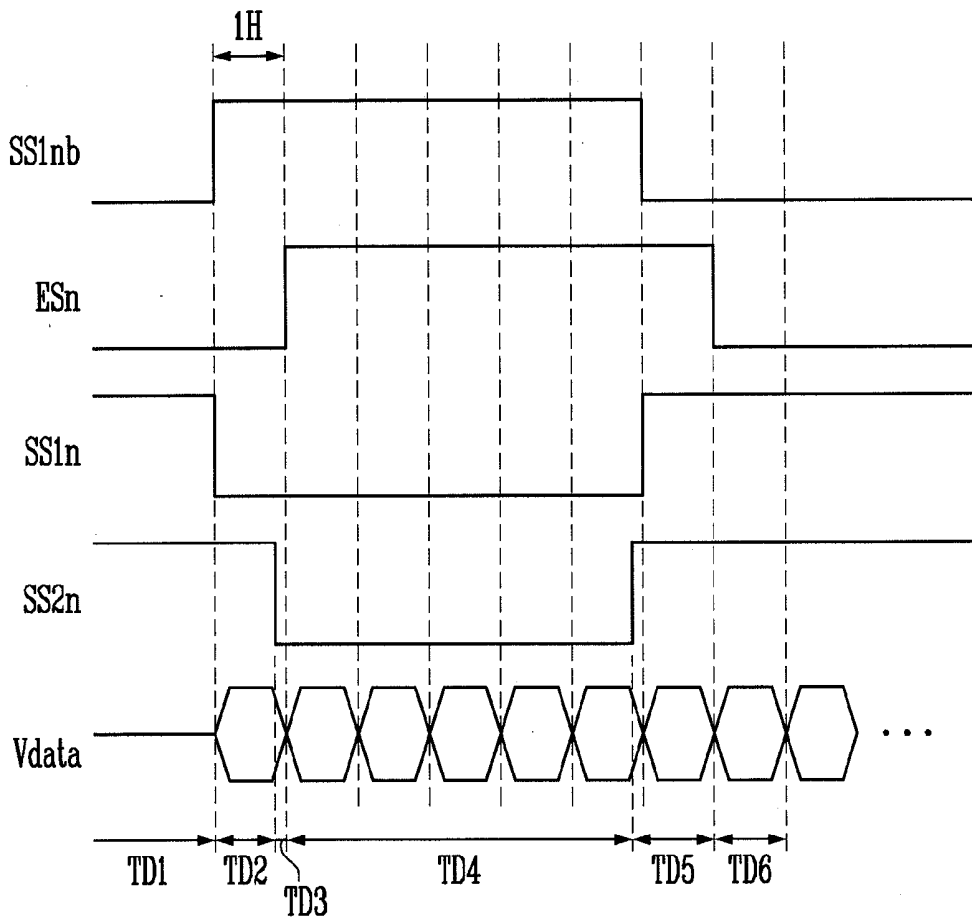

FIG. 5

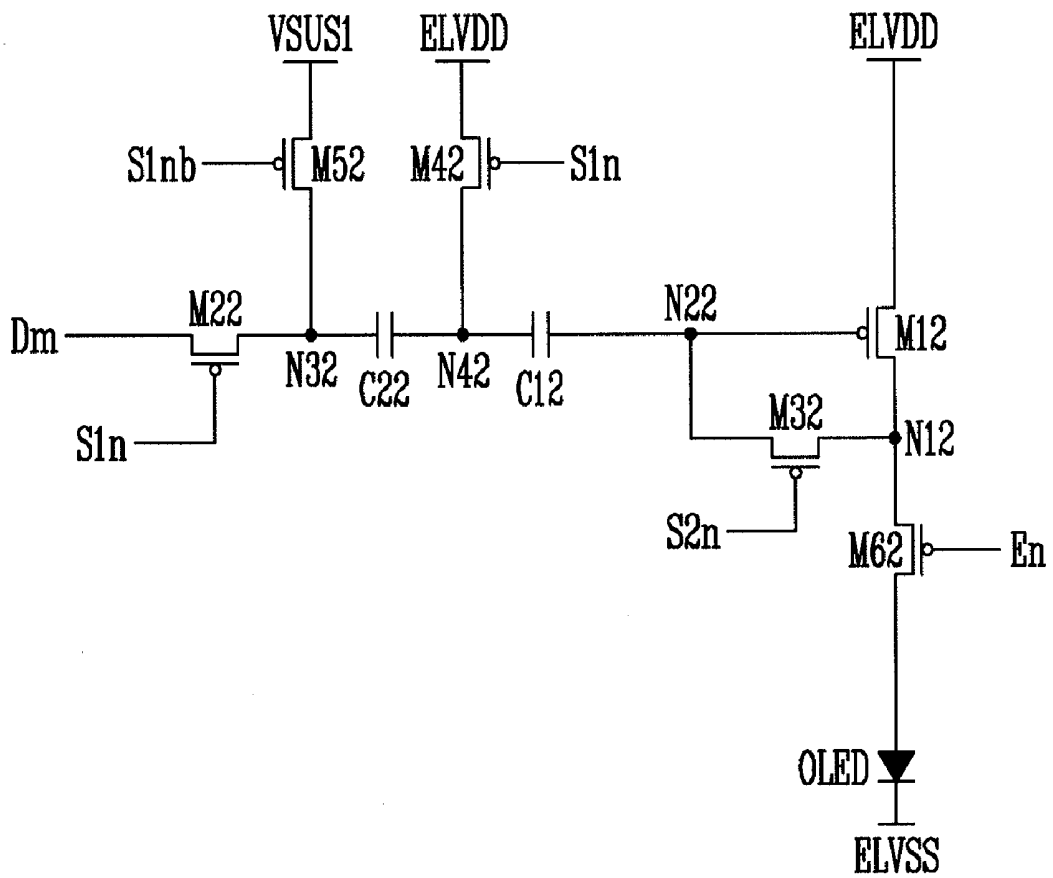

FIG. 6

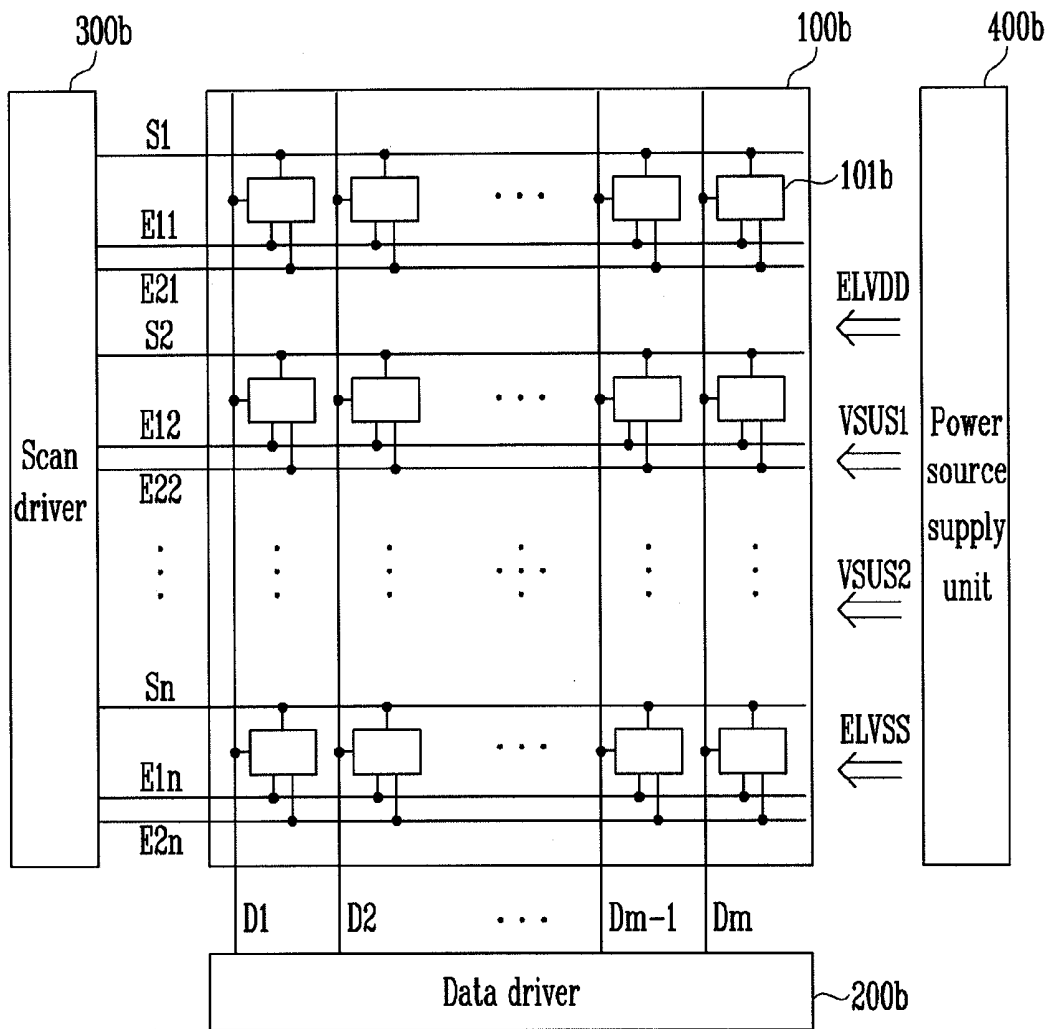

FIG. 7

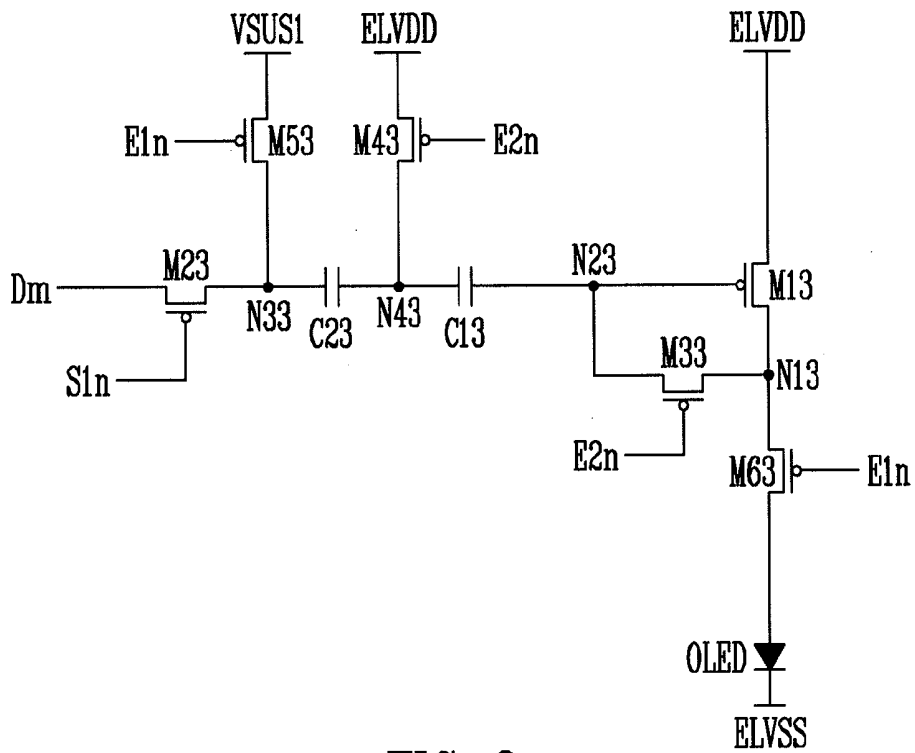

FIG. 8

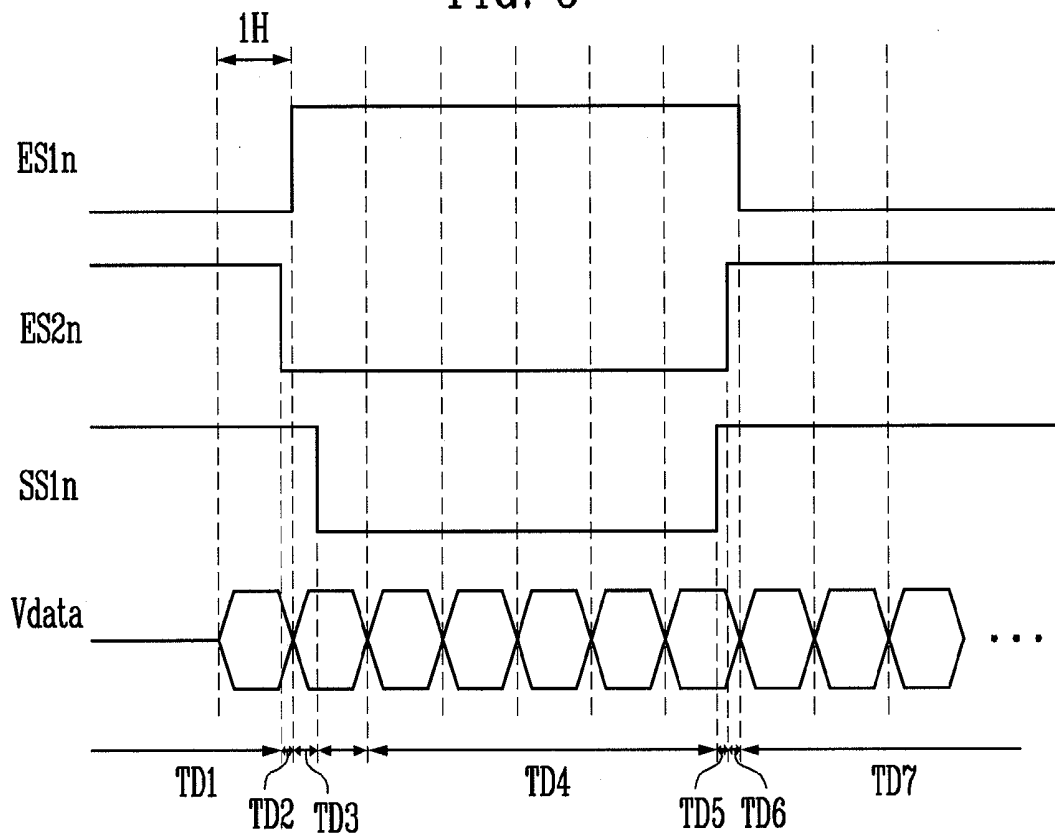

FIG. 9

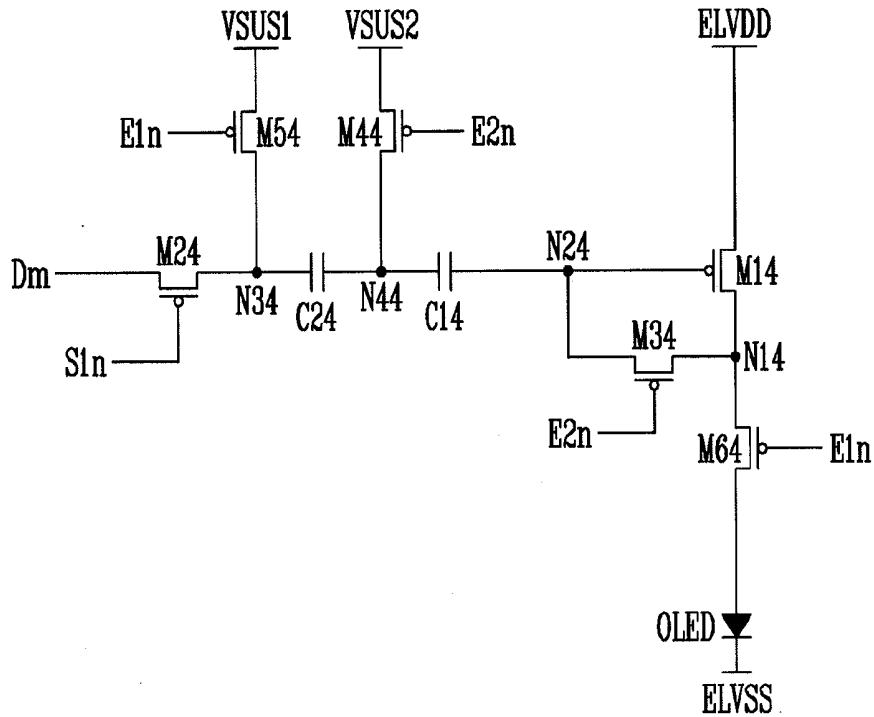
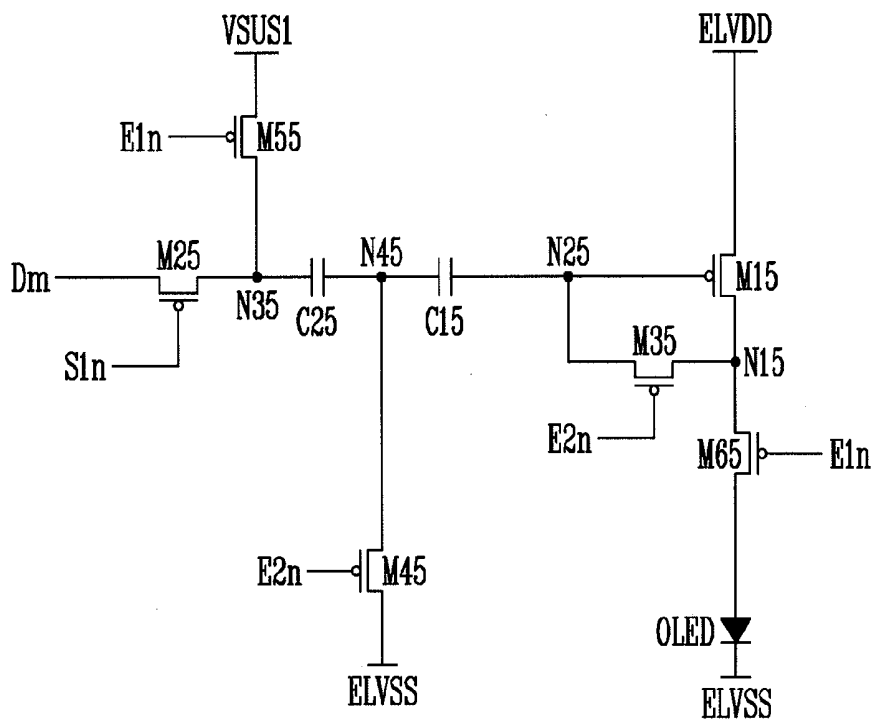

FIG. 10



PIXEL AND ORGANIC LIGHT EMITTING DISPLAY USING THE SAME

CROSS-REFERENCE TO RELATED APPLICATION

[0001] This application claims priority to and the benefit of Korean Patent Application No. 10-2009-009213, filed on Oct. 19, 2009, in the Korean Intellectual Property Office, the entire content of which is incorporated herein by reference.

BACKGROUND

[0002] 1. Field

[0003] The field relates to a pixel and an organic light emitting display using the same, and more particularly, to a pixel suitable for realizing high resolution and high frequency and an organic light emitting display using the same.

[0004] 2. Description of the Related Technology

[0005] Various flat panel displays (FPD) having reduced weight and volume when compared to cathode ray tubes (CRT) are being developed. The FPDs include a liquid crystal display (LCD), a field emission display (FED), a plasma display panel (PDP), and an organic light emitting display.

[0006] The organic light emitting display displays an image using organic light emitting diodes (OLED) that generate light by re-combination of electrons and holes.

[0007] The organic light emitting display is used in the market for personal digital assistants (PDA), MP3 players and mobile telephones due to various advantages such as excellent color reproducibility and small thickness.

[0008] The OLED used for the organic light emitting display includes an anode electrode, a cathode electrode, and a light emitting layer formed between the anode electrode and the cathode electrode. The OLED emits light from the light emitting layer when current flows from the anode electrode to the cathode electrode. The amount of light emitted corresponds to the amount of current.

[0009] FIG. 1 is a circuit diagram illustrating a pixel adopted by a some organic light emitting displays. Referring to FIG. 1, the pixel includes an OLED, a first transistor T1, a second transistor T2, a third transistor T3, a fourth transistor T4, a fifth transistor T5, a sixth transistor T6, and a capacitor Cst. Each of the first to sixth transistors T1 to T6 includes a gate electrode, a source electrode, and a drain electrode. The capacitor Cst includes a first electrode and a second electrode.

[0010] The source electrode of the first transistor T1 is coupled to a first node A, the drain electrode of the first transistor T1 is coupled to a second node B, and the gate electrode of the first transistor T1 is coupled to a third node C.

[0011] The source electrode of the second transistor T2 is coupled to a data line Dm and the drain electrode of the second transistor T2 is coupled to the first node A. The gate electrode of the second transistor T2 is coupled to a first scan line Sn. Therefore, a data signal is transmitted to the first node A by a first scan signal input through the first scan line Sn.

[0012] The source electrode of the third transistor T3 is coupled to the second node B, the drain electrode of the third transistor T3 is coupled to the third node C, and the gate electrode of the third transistor T3 is coupled to the first scan line Sn. When the third transistor T3 is turned on by the first scan signal transmitted through the first scan line, the potential of the second node B is equal to the potential of the third node C.

[0013] The source electrode of the fourth transistor T4 is coupled to an initialization power source Vinit, the drain electrode of the fourth transistor T4 is coupled to the third node C, and the gate electrode of the fourth transistor T4 is coupled to a second scan line Sn-1. The scan signal transmitted to the second scan line Sn-1 transmits the data signal to the pixel in a previous row.

[0014] The source electrode of the fifth transistor T5 is coupled to a first pixel power source line ELVDD, the drain electrode of the fifth transistor T5 is coupled to the first node A, and the gate electrode of the fifth transistor T5 is coupled to an emission control line En. Therefore, the first pixel power source ELVDD is selectively transmitted to the first transistor T1 in accordance with the emission control signal transmitted through the emission control line.

[0015] The source electrode of the sixth switching transistor T6 is coupled to the third node C, the drain electrode of the sixth switching transistor T6 is coupled to the OLED, and the gate electrode of the sixth switching transistor T6 is coupled to the emission control line En. Therefore, the current that flows from the source electrode of the first transistor to the drain electrode of the first transistor is selectively transmitted to the OLED in accordance with the emission control signal transmitted through the emission control line En.

[0016] The first electrode of the capacitor Cst is coupled to the first pixel power source ELVDD and the second electrode of the capacitor Cst is coupled to the third node C. Therefore, when an initialization signal is transmitted to the third node C by the fourth transistor T4, the third node C maintains the initialization voltage because of the capacitor Cst. Then, when the data signal is transmitted to the first transistor T1 by the second transistor T2 and the third transistor T3, the third node C stores the voltage corresponding to the data signal.

[0017] The voltage stored in the third node C is as illustrated in EQUATION 1.

$$\begin{aligned} I_{OLED} &= \frac{\beta}{2}(V_{gs} - V_{th})^2 & \text{[EQUATION 1]} \\ &= \frac{\beta}{2}(V_{data} - ELVDD + V_{th} - V_{th})^2 \\ &= \frac{\beta}{2}(V_{data} - ELVDD)^2 \end{aligned}$$

[0018] wherein, I_{OLED} represents the current that flows through the OLED, V_{gs} represents the voltage applied between the gate electrode of the first transistor T1 and the source electrode of the first transistor T1, ELVDD represents the voltage of the first pixel power source, V_{th} represents the threshold voltage of the first transistor T1, and V_{data} represents the voltage of the data signal.

[0019] According to EQUATION 1, the current flows through the OLED from the first transistor to correspond to the voltage of the data signal and the voltage of the first pixel power source ELVDD, thus, the threshold voltage is compensated for.

[0020] However, since current flows to correspond to the first pixel power source ELVDD and the voltage of the data signal in the pixel, when a difference in the first pixel power source transmitted to the pixels is generated by voltage reduction in the power distribution, the current does not uniformly flow through the pixels.

[0021] In addition, when the organic light emitting display has high resolution and receives a high frequency driving

signal, the length of one horizontal time is reduced. For example, when the organic light emitting display is driven by 60 Hz with resolution of FHD (full high-definition), the length of the one horizontal time is 14.8 μ s. When the organic light emitting display is driven by 120 Hz with resolution of FHD, the length of the one horizontal time is reduced to 7.4 μ s.

[0022] When the length of the one horizontal time is reduced, time for compensating for the threshold voltage is reduced so that picture quality deteriorates.

SUMMARY OF CERTAIN INVENTIVE ASPECTS

[0023] One aspect is a pixel, including an organic light emitting diode (OLED) receiving pixel current flowing from a first pixel power source to a second pixel power source to emit light. The pixel also includes a first transistor, including a gate coupled to a first node, a first electrode coupled to the first pixel power source, and a second electrode coupled to a second node, where the pixel current flows from the first electrode to the second electrode according to a voltage of the gate. The pixel also includes a second transistor for selectively supplying a data signal to a third node, a third transistor for selectively and electrically coupling the gate of the first transistor to the second electrode of the first transistor, a fourth transistor for selectively supplying a voltage of a second compensation power source to a fourth node, and a fifth transistor for selectively supplying a voltage of a first compensation power source to the third node, a sixth transistor for selectively supplying the pixel current to the OLED, a first capacitor positioned between the second node and the fourth node, and a second capacitor positioned between the third node and the fourth node.

[0024] Another aspect is an organic light emitting display, including a pixel unit including a plurality of pixels, a data driver for supplying data signals to the pixels, a power source supply unit for supplying a first pixel power source, a second pixel power source, a first compensation power source, and a second compensation power source to the pixels. The display also includes a scan driver for selectively supplying the data signals, the first pixel power source, the second pixel power source, the first compensation power source, and the second compensation power source to the pixels so that the pixel current corresponding to the data signals flows to the pixels. Each of the pixels include an organic light emitting diode (OLED) receiving pixel current flowing from the first pixel power source to the second pixel power source to emit light, a first transistor, including a gate coupled to a first node, a first electrode coupled to the first pixel power source, and a second electrode coupled to a second node, where the pixel current flows from the first electrode to the second electrode according to a voltage of the gate. The pixel also includes a second transistor for selectively supplying a data signal to a third node, a third transistor for selectively and electrically coupling the gate of the first transistor to the second electrode of the first transistor, a fourth transistor for selectively supplying a voltage of a second compensation power source to a fourth node, a fifth transistor for selectively supplying a voltage of a first compensation power source to the third node, a sixth transistor for selectively supplying the pixel current to the OLED, a first capacitor positioned between the second node

and the fourth node, and a second capacitor positioned between the third node and the fourth node.

BRIEF DESCRIPTION OF THE DRAWINGS

[0025] The accompanying drawings, together with the specification, illustrate exemplary embodiments, and, together with the description, serve to explain certain inventive principles.

[0026] FIG. 1 is a circuit diagram illustrating the pixel adopted by some organic light emitting displays;

[0027] FIG. 2 is a block diagram illustrating an embodiment of an organic light emitting display;

[0028] FIG. 3 is a circuit diagram illustrating an embodiment of the pixel adopted by the organic light emitting display of FIG. 2;

[0029] FIG. 4 is a timing diagram illustrating the operation of the pixel of FIG. 3;

[0030] FIG. 5 is a circuit diagram illustrating an embodiment of the pixel adopted by the organic light emitting display of FIG. 2;

[0031] FIG. 6 is a block diagram illustrating an embodiment of the organic light emitting display;

[0032] FIG. 7 is a circuit diagram illustrating an embodiment of the pixel adopted by the organic light emitting display of FIG. 6;

[0033] FIG. 8 is a timing diagram illustrating the operation of the pixel of FIG. 7;

[0034] FIG. 9 is a circuit diagram illustrating an embodiment of the pixel adopted by the organic light emitting display of FIG. 6; and

[0035] FIG. 10 is a circuit diagram illustrating an embodiment of the pixel adopted by the organic light emitting display of FIG. 6.

DETAILED DESCRIPTION OF CERTAIN INVENTIVE EMBODIMENTS

[0036] Hereinafter, certain exemplary embodiments will be described with reference to the accompanying drawings. When a first element is described as being coupled to a second element, the first element may be not only directly coupled to the second element but may also be indirectly coupled to the second element via a third element. Further, some of the elements that are not essential to the complete understanding of the invention are omitted for clarity. Also, like reference numerals generally refer to like elements throughout.

[0037] FIG. 2 is a block diagram illustrating an embodiment of an organic light emitting display. Referring to FIG. 2, the organic light emitting display includes a pixel unit **100a**, a data driver **200a**, a scan driver **300a**, and a power source supply unit **400a**.

[0038] The pixel unit **100a** includes a plurality of pixels **101a** including m data lines $D1, D2, \dots, D_{m-1},$ and D_m , n first scan lines $S11, S12, \dots, S1_{n-1},$ and $S1_n$, n first sub-scan lines $S11b, S12b, \dots, S1_{n-1}b,$ and $S1_nb$, n second scan lines $S21, S22, \dots, S2_{n-1},$ and $S2_n$, and n emission control lines $E1, E2, \dots, E_{n-1},$ and E_n and formed in the regions defined by the m data lines $D1, D2, \dots, D_{m-1},$ and D_m , the n first scan lines $S11, S12, \dots, S1_{n-1},$ and $S1_n$, the n second scan lines $S21, S22, \dots, S2_{n-1},$ and $S2_n$, the n first sub-scan lines $S11b, S12b, \dots, S1_{n-1}b,$ and $S1_nb$, and the n emission control lines $E1, E2, \dots, E_{n-1},$ and E_n . The pixels **101a** include pixel circuits and organic light emitting diodes (OLED), generate the data signals transmitted from the pixel circuits to the m

data lines $D1, D2, \dots, D_{m-1}$, and D_m , the scan signals transmitted through the n first scan lines $S11, S12, \dots, S1_{n-1}$, and $S1_n$, the n first sub-scan lines $S11b, S12b, \dots, S1_{n-1}b$, and $S1_nb$, and the n second scan lines $S21, S22, \dots, S2_{n-1}$, and $S2_n$, and the pixel current that flows through the pixels by sub-scan signals and emission control signals, and controls the flow of the pixel current to the OLEDs. In addition, the pixel receives a first pixel power source ELVDD, a second pixel power source ELVSS, a first compensation power source VSUS1, and a second compensation power source VSUS2 so that the current corresponding to the data signal may flow through the pixel.

[0039] The data driver **200a** coupled to the m data lines $D1, D2, \dots, D_{m-1}$, and D_m generates the data signals and sequentially transmits the data signals in a row to the m data lines $D1, D2, \dots, D_{m-1}$, and D_m .

[0040] The scan driver **300a** coupled to the n first scan lines $S11, S12, \dots, S1_{n-1}$, and $S1_n$, the n first sub-scan lines $S11b, S12b, \dots, S1_{n-1}b$, and $S1_nb$, and the n second scan lines $S21, S22, \dots, S2_{n-1}$, and $S2_n$ generates the first scan signals, the first sub-scan signals, and the second scan signals and transmits the first scan signals, the first sub-scan signals, and the second scan signals to the n first scan lines $S11, S12, \dots, S1_{n-1}$, and $S1_n$, the n first sub-scan lines $S11b, S12b, \dots, S1_{n-1}b$, and $S1_nb$, and the n second scan lines $S21, S22, \dots, S2_{n-1}$, and $S2_n$.

[0041] In addition, the scan driver **300a** coupled to n emission control lines $E1, E2, \dots, E_{n-1}$, and E_n generates the emission control signals and transmits the emission control signals to the n emission control lines $E1, E2, \dots, E_{n-1}$, and E_n . The emission control signals are illustrated to be generated by the scan driver **300a**. However, the emission control signals may be generated by an additional driver, the emission control signals may be transmitted to the n emission control lines $E1, E2, \dots, E_{n-1}$, and E_n .

[0042] The power source supply unit **400a** generates the first pixel power source ELVDD, the second pixel power source ELVSS, the first compensation power source VSUS1, and the second compensation power source VSUS2 and transmits the first pixel power source ELVDD, the second pixel power source ELVSS, the first compensation power source VSUS1, and the second compensation power source VSUS2 to the pixel unit **100a**. In some embodiments, the first compensation power source VSUS1 has substantially the same voltage as first pixel power source ELVDD. In some embodiments, the second compensation power source VSUS2 has substantially the same voltage as second pixel power source ELVSS.

[0043] FIG. 3 is a circuit diagram illustrating an embodiment of the pixel adopted by the organic light emitting display of FIG. 2. Referring to FIG. 3, the pixel **101a** includes first to sixth transistors $M11$ to $M61$, first and second capacitors $C11$ and $C21$, and an organic light emitting diode OLED. The first pixel power source ELVDD and the second pixel power source ELVSS having a lower voltage than the first pixel power source ELVDD are transmitted to the pixel. In addition, the first compensation power source VSUS1 and the second compensation power source VSUS2 are transmitted to the pixel. The pixel is coupled to the data line D_m , the first scan line $S1_n$, the second scan line $S2_n$, the first sub-scan line $S1_nb$, and the emission control line E_n . In addition, each transistor includes three electrodes of a source, a drain, and a gate. When the source is referred to as a first electrode, the drain may be referred to as a second electrode.

[0044] In the first transistor $M11$, the source is coupled to the first pixel power source ELVDD, the drain is coupled to a first node $N11$, and the gate is coupled to a second node $N21$.

[0045] In the second transistor $M21$, the source is coupled to the data line D_m , the drain is coupled to a third node $N31$, and the gate is coupled to the first scan line $S1_n$.

[0046] In the third transistor $M31$, the source is coupled to the first node $N11$, the drain is coupled to a second node $N21$, and the gate is coupled to the second scan line $S2_n$.

[0047] In the fourth transistor $M41$, the source is coupled to the second compensation power source VSUS2, the drain is coupled to a fourth node $N41$, and the gate is coupled to the first scan line $S1_n$.

[0048] In the fifth transistor $M51$, the source is coupled to the first compensation power source VSUS1, the drain is coupled to the third node $N31$, and the gate is coupled to the first sub-scan line $S1_nb$.

[0049] In the sixth transistor $M61$, the source is coupled to the first node $N11$, the drain is coupled to the OLED, and the gate is coupled to the emission control line E_n .

[0050] In the first capacitor $C11$, the first electrode is coupled to the second node $N21$ and the second electrode is coupled to the fourth node $N41$.

[0051] In the second capacitor $C21$, the first electrode is coupled to the fourth node $N41$ and the second electrode is coupled to the third node $N31$.

[0052] In the OLED, an anode is coupled to the sixth transistor $M61$ and a cathode is coupled to the second pixel power source ELVSS.

[0053] FIG. 4 is a timing diagram illustrating the operation of the pixel of FIG. 3. Referring to FIG. 4, the signal input to the pixel **101a** includes a first scan signal $SS1_n$, a first sub-scan signal $SS1_nb$, a second scan signal $SS2_n$, and an emission control signal ES_n .

[0054] First, in a first period $TD1$, the first scan signal $SS1_n$ is in a high level, the first sub-scan signal $SS1_nb$ is in a low level, the second scan signal $SS2_n$ is in a high level, and the emission control signal ES_n is in a low level. Therefore, the fifth transistor $M51$ and the sixth transistor $M61$ are turned on and the second transistor $M21$, the third transistor $M31$, and the fourth transistor $M41$ are turned off. Then, the first compensation power source VSUS1 is transmitted to the third node $N31$. The voltage of the first compensation power source VSUS1 is set to correspond to the voltage of the data signal that displays black so that the first compensation power source VSUS1 is transmitted to the third node $N31$ and, although the voltage of the second node $N21$ changes, no current flows from the source of the first transistor $M11$ to the drain of the first transistor $M11$. Therefore, although the sixth transistor $M61$ is turned on, no current flows to the OLED.

[0055] In a second period $TD2$, the first scan signal $SS1_n$ is in a low level, the first sub-scan signal $SS1_nb$ is in a high level, the second scan signal $SS2_n$ is in a high level, and the emission control signal ES_n is in a low level. Therefore, the second transistor $M21$, the fourth transistor $M41$, and the sixth transistor $M61$ are on and the third transistor $M31$ and the fifth transistor $M51$ are off. When the second transistor $M21$ and the fourth transistor $M41$ are on, the data signal V_{data} is transmitted to the third node $N31$. The second compensation power source VSUS2 is transmitted to the node $N41$. The second compensation power source VSUS2 is set to correspond to the voltage of the data signal that displays black. Accordingly, although the sixth transistor $M61$ is turned on, no current flows to the OLED.

[0056] In a third period TD3, the first scan signal SS1n is in a low level, the first sub-scan signal SS1nb is in a high level, and the emission control signal ESn is in a low level. Accordingly, the level of the second scan signal SS2n is changed from a high level to a low level. Therefore, the second transistor M21, the third transistor M31, the fourth transistor M41, and the sixth transistor M61 are turned on and the fifth transistor M51 is turned off. Therefore, the voltage of the data signal Vdata and the voltage of the second compensation power source VSUS2 are continuously maintained in the third node N31 and the fourth node N41. Then, the second pixel power source ELVSS is transmitted to the second node N21 by the third transistor M31. The second node N21 is initialized by the second pixel power source ELVSS. Because the sixth transistor M61 is turned on, current may flow to the OLED. However, since the third period TD3 is maintained for a very short time, the light emitted by the OLED is not sensed.

[0057] Then, in a fourth period TD4, the first scan signal SS1n and the second scan signal SS2n are in a low level, the first sub-scan signal SS1nb is in a high level, and the level of the emission control signal is changed to a high level. Since the emission control signal is in a high level, the sixth transistor M61 is off so that the flow of current to the OLED is blocked. In addition, since the second transistor M21 and the fourth transistor M41 are on, the voltage of the data signal Vdata and the voltage of the second compensation power source VSUS2 are maintained in the third node N31 and the fourth node N41, respectively. Accordingly, the first transistor M11 is diode coupled by the third transistor M31 so that the voltage corresponding to EQUATION 2 is transmitted to the gate of the first transistor M11.

$$Vg = ELVDD - Vth \quad \text{[EQUATION 2]}$$

[0058] wherein, Vg represents the gate voltage of the first transistor M11, ELVDD represents the voltage of the first pixel power source ELVDD, and Vth represents the threshold voltage of the first transistor M11.

[0059] The voltage corresponding to the EQUATION 2 is maintained at the second node N21 by the first capacitor C11. In addition, the duration of the fourth period TD4 may vary. In FIG. 4, the duration of the fourth period TD4 is illustrated as about 5H. However, if the threshold voltage may be sufficiently compensated for, the time may be shorter than 5H.

[0060] In a fifth period TD5, the level of the second scan signal SS2n is changed to a high level, the first scan signal SS1n is in a high level and the first sub-scan signal SS1nb is in a low level. In addition, the emission control signal ESn is in a high level. Because the voltage of the third node N31 is changed from the voltage of the data signal Vdata to the voltage of the first compensation power source VSUS1 and the fourth transistor M41 is turned off, the voltage of the fourth node N41 and the voltage of the second node N21 change by a difference between the voltage of the data signal and the voltage of the first compensation power source VSUS1.

[0061] Therefore, the voltage of the second node N21 corresponds to EQUATION 3.

$$Vg = ELVDD - Vth - (Vdata - VSUS1) \quad \text{[EQUATION 3]}$$

[0062] wherein, Vg represents the gate voltage of the first transistor M11, ELVDD represents the voltage of the first pixel power source ELVDD, Vth represents the threshold voltage of the first transistor M11, Vdata represents the voltage of the data signal Vdata, and VSUS1 represents the voltage of the first compensation power source VSUS1.

[0063] In a sixth period TD6, the first scan signal SS1n and the second scan signal SS2n are in a high level, and the first sub-scan signal SS1nb and the emission control signal ESn are in a high level. At this time, the sixth transistor M61 is turned on so that the current corresponding to the voltage transmitted to the gate of the first transistor M11 flows to the OLED. In addition, since the first compensation power source VSUS1 is transmitted to the third node N31, the voltage of the second node N21 that is the voltage of the gate of the first transistor M11 formed in the fifth period TD5 does not change.

[0064] Therefore, the current that flows to the OLED is expressed by the following EQUATION 4.

$$I_{ds} = \beta(V_{gs} - V_{th})^2 = \beta(ELVDD - (ELVDD - V_{th} + VSUS1 - V_{data}) - V_{th})^2 = \beta(V_{data} - VSUS1)^2 \quad \text{[EQUATION 4]}$$

[0065] wherein, Ids represents the current that flows through the OLED, β represents a constant, and Vgs represents a voltage between the source of the first transistor M11 and the gate of the first transistor M11.

[0066] Therefore, the current that flows through the OLED corresponds to the voltage of the first compensation power source VSUS1 and the voltage of the data signal Vdata. That is, reduction in the threshold voltage of the first transistor M11 and the voltage of the first pixel power source ELVDD are compensated for.

[0067] In addition, the gate voltage of the first transistor M11 does not change by the voltage of the first compensation power source VSUS1 while the OLED emits light so that, although the voltage of the data signal Vdata that flows through the data line Dm changes, the voltage of the gate of the first transistor M11 is not affected. Therefore, cross-talk in accordance with a change in the voltage of the data signal Vdata that flows through the data line Dm may be prevented.

[0068] FIG. 5 is a circuit diagram illustrating an embodiment of the pixel adopted by the organic light emitting display of FIG. 2. Referring to FIG. 5, the pixel 101a includes first to sixth transistors M12 to M62, first and second capacitors C12 and C22, and an OLED. The first pixel power source ELVDD and the second pixel power source ELVSS having a lower voltage than the first pixel power source ELVDD are transmitted to the pixel. In addition, the first compensation power source VSUS1 is transmitted to the pixel. The pixel is coupled to the data line Dm, the first scan line S1n, the second scan line S2n, the first sub-scan line S1nb, and the emission control line En.

[0069] In the first transistor M12, the source is coupled to the first pixel power source ELVDD, the drain is coupled to a first node N12, and the gate is coupled to a second node N22.

[0070] In the second transistor M22, the source is coupled to the data line Dm, the drain is coupled to a third node N32, and the gate is coupled to the first scan line S1n.

[0071] In the third transistor M32, the source is coupled to the first node N12, the drain is coupled to a second node N22, and the gate is coupled to the second scan line S2n.

[0072] In the fourth transistor M42, the source is coupled to the first pixel power source ELVDD, the drain is coupled to a fourth node N42, and the gate is coupled to the first scan line S1n.

[0073] In the fifth transistor M52, the source is coupled to the first compensation power source VSUS1, the drain is coupled to the third node N32, and the gate is coupled to the first sub-scan line S1nb.

[0074] In the sixth transistor **M62**, the source is coupled to the first node **N12**, the drain is coupled to the OLED, and the gate is coupled to the emission control line **En**.

[0075] In the first capacitor **C12**, the first electrode is coupled to the second node **N22** and the second electrode is coupled to the fourth node **N42**.

[0076] In the second capacitor **C22**, the first electrode is coupled to the fourth node **N42** and the second electrode is coupled to the third node **N32**.

[0077] In the OLED, an anode is coupled to the sixth transistor **M62** and a cathode is coupled to the second pixel power source **ELVSS**.

[0078] The pixel having the above structure is driven by the signals illustrated in FIG. 4. Unlike the pixel illustrated in FIG. 3, not the second compensation power source **VSUS2** but the first pixel power source **ELVDD** is used.

[0079] FIG. 6 is a block diagram illustrating an embodiment of the organic light emitting display. Referring to FIG. 6, the organic light emitting display includes a pixel unit **100b**, a data driver **200b**, a scan driver **300b**, and a power source supply unit **400b**.

[0080] The pixel unit **100b** includes a plurality of pixels **101b** including m data lines **D1**, **D2**, . . . , **Dm-1**, and **Dm**, n first scan lines **S11**, **S12**, . . . , **S1n-1**, and **S1n**, n first emission control lines **E11**, **E12**, . . . , **E1n-1**, and **E1n**, and n second emission control lines **E21**, **E22**, . . . , **E2n-1**, and **E2n** and formed in the regions defined by the m data lines **D1**, **D2**, . . . , **Dm-1**, and **Dm**, the n first scan lines **S11**, **S12**, . . . , **S1n-1**, and **S1n**, the n first emission control lines **E11**, **E12**, . . . , **E1n-1**, and **E1n**, and the n second emission control lines **E21**, **E22**, . . . , **E2n-1**, and **E2n**. The pixels **101b** include pixel circuits and organic light emitting diodes (OLED), generate the data signals transmitted from the pixel circuits to the m data lines **D1**, **D2**, . . . , **Dm-1**, and **Dm**, the scan signals transmitted through the n first scan lines **S11**, **S12**, . . . , **S1n-1**, and **S1n**, the n first emission control lines **E11**, **E12**, . . . , **E1n-1**, and **E1n**, and the n second emission control lines **E21**, **E22**, . . . , **E2n-1**, and **E2n**, and the pixel current that flows through the pixels to correspond to the data signals by the first emission control signal and the second emission control signal, and controls the flow of the pixel current to the OLEDs. In addition, the pixel receives a first pixel power source **ELVDD**, a second pixel power source **ELVSS**, a first compensation power source **VSUS1**, and a second compensation power source **VSUS2** so that the current corresponding to the data signal may flow through the pixel.

[0081] The data driver **200b** coupled to the m data lines **D1**, **D2**, . . . , **Dm-1**, and **Dm** generates the data signals and sequentially transmits the data signals in a row to the m data lines **D1**, **D2**, . . . , **Dm-1**, and **Dm**.

[0082] The scan driver **300b** coupled to the n first scan lines **S11**, **S12**, . . . , **S1n-1**, and **S1n**, the n first emission control lines **E11**, **E12**, . . . , **E1n-1**, and **E1n**, and the n second emission control lines **E21**, **E22**, . . . , **E2n-1**, and **E2n** generates the first scan signals, the first emission control signals, and the second emission control signals and transmits the first scan signals, the first emission control signals, and the second emission control signals to the n first scan lines **S11**, **S12**, . . . , **S1n-1**, and **S1n**, the n first emission control lines **E11**, **E12**, . . . , **E1n-1**, and **E1n**, and the n second emission control lines **E21**, **E22**, . . . , **E2n-1**, and **E2n**.

[0083] The emission control signals are illustrated as being generated by the scan driver **300b**. However, an additional

driver may generate the emission control signals for transmission to the n emission control lines **E1**, **E2**, . . . , **En-1**, and **En**.

[0084] The power source supply unit **400b** generates the first pixel power source **ELVDD**, the second pixel power source **ELVSS**, the first compensation power source **VSUS1**, and the second compensation power source **VSUS2** and transmits the first pixel power source **ELVDD**, the second pixel power source **ELVSS**, the first compensation power source **VSUS1**, and the second compensation power source **VSUS2**, if necessary, to the pixel unit **100b**.

[0085] FIG. 7 is a circuit diagram illustrating an embodiment of the pixel adopted by the organic light emitting display of FIG. 6. Referring to FIG. 7, the pixel **101b** includes first to sixth transistors **M13** to **M63**, first and second capacitors **C13** and **C23**, and an OLED. The first pixel power source **ELVDD** and the second pixel power source **ELVSS** having a lower voltage than the first pixel power source **ELVDD** are transmitted to the pixel. In addition, the first compensation power source **VSUS1** is transmitted to the pixel. The data line **Dm**, the first scan line **S1n**, the first emission control line **E1n**, and the second emission control line **E2n** are transmitted to the pixel. In addition, each transistor includes three electrodes of a source, a drain, and a gate. When the source is referred to as a first electrode, the drain may be referred to as a second electrode.

[0086] In the first transistor **M13**, the source is coupled to the first pixel power source **ELVDD**, the drain is coupled to a first node **N13**, and the gate is coupled to a second node **N23**.

[0087] In the second transistor **M23**, the source is coupled to the data line **Dm**, the drain is coupled to a third node **N33**, and the gate is coupled to the first scan line **S1n**.

[0088] In the third transistor **M33**, the source is coupled to the first node **N13**, the drain is coupled to a second node **N23**, and the gate is coupled to the second emission control line **E2n**.

[0089] In the fourth transistor **M43**, the source is coupled to the first pixel power source **ELVDD**, the drain is coupled to a fourth node **N44**, and the gate is coupled to the second emission control line **E2n**.

[0090] In the fifth transistor **M53**, the source is coupled to the first compensation power source **VSUS1**, the drain is coupled to the third node **N33**, and the gate is coupled to the first emission control line **E1n**.

[0091] In the sixth transistor **M63**, the source is coupled to the first node **N13**, the drain is coupled to the OLED, and the gate is coupled to the first emission control line **E1n**.

[0092] In the first capacitor **C13**, the first electrode is coupled to the second node **N23** and the second electrode is coupled to the fourth node **N43**.

[0093] In the second capacitor **C23**, the first electrode is coupled to the fourth node **N43** and the second electrode is coupled to the third node **N33**.

[0094] In the OLED, an anode is coupled to the sixth transistor **M63** and a cathode is coupled to the second pixel power source **ELVSS**.

[0095] FIG. 8 is a timing diagram illustrating the operation of the pixel of FIG. 7. Referring to FIG. 8, the signal input to the pixel **101b** includes the first scan signal **SS1n**, the first emission control signal **ES1n**, and the second emission control signal **ES2n**.

[0096] During a first period **TD1**, the first scan signal **SS1n** and the second emission control signal **ES2n** are in a high level and the first emission control signal **ES1n** is in a low

level. Therefore, the fifth transistor M53 and the sixth transistor M63 are on and the second transistor M23, the third transistor M33, and the fourth transistor M43 are off. The first compensation power source VSUS1 is transmitted to the third node N33. The voltage of the first compensation power source VSUS1 is set to correspond to the voltage of the data signal that displays black. Although the voltage of the second node N23 that is the gate of the first transistor M13 is changed by the first compensation power source VSUS1, the voltage corresponding to at least the first compensation power source VSUS1 is applied to the second node N23 so that no current flows from the source of the first transistor M13 to the drain of the first transistor M13. Therefore, although the sixth transistor M63 is on, no current flows to the OLED.

[0097] In a second period TD2, the first scan signal SS1n is in a high level and the first emission control signal ES1n and the second emission control signal ES2n are in a low level. Therefore, the second transistor M21 is off and the third transistor M33, the fourth transistor M43, the fifth transistor M53, and the sixth transistor M63 are on. Since the third transistor M33 and the sixth transistor M63 are on, the second pixel power source ELVSS is transmitted to the second node N23. Because the fourth transistor M43 and the fifth transistor M53 are on, the first compensation power source VSUS1 and the first pixel power source ELVDD are transmitted to the third node N33 and the fourth node N43, respectively.

[0098] During a third period TD3, the first scan signal SS1n and the first emission control signal ES1n are in a high level and the second emission control signal ES2n is in a low level. At this time, the second transistor M23, the fifth transistor M53, and the sixth transistor M63 are off and the third transistor M33 and the fourth transistor M43 are on. Since the fourth transistor M43 is on, the first pixel power source ELVDD is transmitted to the fourth node N43, and the voltage of the second node N23 does not change. However, because the sixth transistor M63 is turned off, no current flows to the OLED.

[0099] During a fourth period TD4, the first scan signal SS1n and the second emission control signal ES2n are in a low level and the first emission control signal ES1n is in a high level. Since the first emission control signal ES1n is in a high level, the sixth transistor M63 is turned off so that the flow of current to the OLED is blocked. In addition, since the second transistor M23 is on, the data signal Vdata is supplied to the third node N33. In addition, since the fourth transistor M43 is on, the first pixel power source ELVDD is transmitted to the fourth node N43. Since the third transistor M33 is turned on, the first transistor M13 is diode coupled so that the voltage corresponding to the EQUATION 2 is transmitted to the gate of the first transistor M13. The second node N23 is coupled to the gate of the first transistor M13 so that the voltage corresponding to the EQUATION 2 is maintained by the first capacitor C13. In addition, the length of the fourth period TD4 may vary. In FIG. 8, the length of the fourth period TD4 is illustrated as 6H. However, if the threshold voltage may be sufficiently compensated for, the time may be shorter than 6H.

[0100] Then, in a fifth period TD5, the level of the first scan signal SS1n is changed to a high level. Because the first scan signal SS1n is in a high level, the second transistor M23 is turned off so that the data signal Vdata is not transmitted to the third node N33. However, the voltage of the second node N23 corresponding to the EQUATION 2 is continuously maintained.

[0101] Then, in a sixth period TD6, the first scan signal SS1n, the first emission control signal ES1n, and the second emission control signal ES2n are in a high level.

[0102] During a seventh period TD7, the first scan signal SS1n and the second emission control signal ES2n are in a high level and the first emission control signal ES1n is in a low level. Therefore, the voltage of the third node N33 is transited from the voltage of the data signal Vdata to the voltage of the first compensation power source VSUS1. At this time, since the fourth transistor M43 is turned off, the voltage of the fourth node N43 and the voltage of the second node N23 change by a difference between the voltage of the data signal and the voltage of the first compensation power source VSUS1.

[0103] Therefore, the voltage of the second node N23 corresponds to the EQUATION 3.

[0104] Therefore, the current that flows to the OLED is expressed by the EQUATION 4.

[0105] Therefore, the current that flows through the OLED corresponds to the voltage of the first compensation power source VSUS1 and the voltage of the data signal Vdata. That is, the threshold voltage of the first transistor M13 and the voltage of the first pixel power source ELVDD is compensated for.

[0106] In addition, the gate voltage of the first transistor M13 is not changed by the voltage of the first compensation power source VSUS1 while the OLED emits light so that, although the voltage of the data signal Vdata that flows to the data line Dm changes, the gate voltage of the first transistor M13 is not affected. Therefore, cross-talk in accordance with a change in the voltage of the data signal Vdata that flows through the data line Dm may be prevented.

[0107] FIG. 9 is a circuit diagram illustrating an embodiment of the pixel adopted by the organic light emitting display of FIG. 6. Referring to FIG. 9, the pixel 101b includes first to sixth transistors M14 to M64, first and second capacitors C14 and C24, and an OLED. The first pixel power source ELVDD and the second pixel power source ELVSS having a lower voltage than the first pixel power source ELVDD are transmitted to the pixel. In addition, the first compensation power source VSUS1 and the second compensation power source VSUS2 are transmitted to the pixel. The pixel is coupled to the data line Dm, the first scan line S1n, the first emission control line E1n, and the second emission control line E2n.

[0108] In the first transistor M14, the source is coupled to the first pixel power source ELVDD, the drain is coupled to a first node N14, and the gate is coupled to a second node N24.

[0109] In the second transistor M24, the source is coupled to the data line Dm, the drain is coupled to a third node N34, and the gate is coupled to the first scan line S1n.

[0110] In the third transistor M34, the source is coupled to the first node N14, the drain is coupled to the second node N24, and the gate is coupled to the first emission control line E1n.

[0111] In the fourth transistor M44, the source is coupled to the second compensation power source VSUS2, the drain is coupled to the fourth node N44, and the gate is coupled to the second emission control line E2n.

[0112] In the fifth transistor M54, the source is coupled to the first compensation power source VSUS1, the drain is coupled to the third node N34, and the gate is coupled to the first emission control line E1n.

[0113] In the sixth transistor M64, the source is coupled to the first node N14, the drain is coupled to the OLED, and the gate is coupled to the first emission control line E1n.

[0114] In the first capacitor C14, the first electrode is coupled to the second node N24 and the second electrode is coupled to the fourth node N44.

[0115] In the second capacitor C24, the first electrode is coupled to the fourth node N44 and the second electrode is coupled to the third node N34.

[0116] In the OLED, an anode is coupled to the sixth transistor M64 and a cathode is coupled to the second pixel power source ELVSS.

[0117] The pixel having the above structure is driven by the signals illustrated in FIG. 8. Unlike the pixel illustrated in FIG. 7, the second compensation power source VSUS2 is used for the fourth transistor M44, and not the first compensation power source ELVDD.

[0118] FIG. 10 is a circuit diagram illustrating an embodiment of the pixel adopted by the organic light emitting display of FIG. 6. Referring to FIG. 10, the pixel 101b includes first to sixth transistors M15 to M65, first and second capacitors C15 and C25, and an OLED. The first pixel power source ELVDD and the second pixel power source ELVSS having a lower voltage than the first pixel power source ELVDD are transmitted to the pixel. In addition, the first compensation power source VSUS1 is transmitted to the pixel. The pixel is coupled to the data line Dm, the first scan line S1n, the first emission control line E1n, and the second emission control line E2n.

[0119] In the first transistor M15, the source is coupled to the first pixel power source ELVDD, the drain is coupled to a first node N15, and the gate is coupled to a second node N25.

[0120] In the second transistor M25, the source is coupled to the data line Dm, the drain is coupled to a third node N35, and the gate is coupled to the first scan line S1n.

[0121] In the third transistor M35, the source is coupled to the first node N15, the drain is coupled to the second node N25, and the gate is coupled to the second scan line S2n.

[0122] In the fourth transistor M45, the source is coupled to the second pixel power source ELVSS, the drain is coupled to the fourth node N45, and the gate is coupled to the second emission control line E2n.

[0123] In the fifth transistor M55, the source is coupled to the first compensation power source VSUS1, the drain is coupled to the third node N35, and the gate is coupled to the first emission control line E1n.

[0124] In the sixth transistor M65, the source is coupled to the first node N15, the drain is coupled to the OLED, and the gate is coupled to the first emission control line E1n.

[0125] In the first capacitor C15, the first electrode is coupled to the second node N25 and the second electrode is coupled to the fourth node N45.

[0126] In the second capacitor C25, the first electrode is coupled to the fourth node N45 and the second electrode is coupled to the third node N35.

[0127] In the OLED, an anode is coupled to the sixth transistor M65 and a cathode is coupled to the second pixel power source ELVSS.

[0128] The pixel having the above structure is driven by the signals illustrated in FIG. 8. Unlike the pixel illustrated in FIG. 7, the second pixel power source ELVSS is used for the fourth transistor M45, and not the first pixel power source ELVDD.

[0129] While the present invention has been described in connection with certain exemplary embodiments, it is to be understood that the invention is not limited to the disclosed embodiments, but, on the contrary, is intended to cover various modifications and equivalent arrangements.

What is claimed is:

1. A pixel, comprising:

an organic light emitting diode (OLED) receiving pixel current flowing from a first pixel power source to a second pixel power source to emit light;

a first transistor, comprising:

a gate coupled to a first node;

a first electrode coupled to the first pixel power source; and

a second electrode coupled to a second node,

wherein the pixel current flows from the first electrode to the second electrode according to a voltage of the gate;

a second transistor for selectively supplying a data signal to a third node;

a third transistor for selectively and electrically coupling the gate of the first transistor to the second electrode of the first transistor;

a fourth transistor for selectively supplying a voltage of a second compensation power source to a fourth node;

a fifth transistor for selectively supplying a voltage of a first compensation power source to the third node;

a sixth transistor for selectively supplying the pixel current to the OLED;

a first capacitor positioned between the second node and the fourth node; and

a second capacitor positioned between the third node and the fourth node.

2. The pixel as claimed in claim 1, wherein the voltage of the first compensation power source is a voltage of the data signal for displaying black.

3. The pixel as claimed in claim 1, wherein the voltage of the first compensation power source is substantially equal to the voltage of the first pixel power source.

4. The pixel as claimed in claim 1, wherein the voltage of the second compensation power source is substantially equal to the voltage of the second pixel power source.

5. The pixel as claimed in claim 1,

wherein turning on and off the second transistor and the fourth transistor is determined by a first scan signal,

wherein turning on and off the third transistor is determined by a second scan signal,

wherein turning on and off the fifth transistor is determined by a first sub-scan signal, and

wherein turning on and off of the sixth transistor is determined by an emission control signal.

6. The pixel as claimed in claim 1,

wherein turning on and off the second transistor is determined by the first scan signal,

wherein turning on and off the third transistor and the fourth transistor is determined by a second emission control signal, and

wherein turning on and off the fifth transistor and the sixth transistor is determined by a first emission control signal.

7. The pixel as claimed in claim 5, wherein, after the first scan signal becomes a turn-on signal, the second scan signal becomes a turn-on signal and the emission control signal becomes a turn-off signal, and wherein, after the second scan signal becomes a turn-off signal, the first scan signal becomes a turn-off signal and the emission control signal becomes a turn-on signal.
8. The pixel as claimed in claim 6, wherein the first scan signal has a turn-on period in a period where the first emission control signal is turned off, and wherein the first emission control signal becomes a turn-off signal after the second emission control signal becomes a turn-on signal, and becomes a turn-on signal after the second emission control signal becomes a turn-off signal.
9. The pixel as claimed in claim 5, wherein pixel driving periods comprise:
- a first period in which the first sub-scan signal and the emission control signal are in a low level and the first scan signal and the second scan signal are in a high level;
 - a second period in which the first scan signal and the emission control signal are in a low level and the first sub-scan signal and the second scan signal are in a high level;
 - a third period in which the first scan signal, the second scan signal, and the emission control signal are in a low level, and the first sub-scan signal is in a high level;
 - a fourth period in which the first scan signal and the second scan signal are in a low level and the first sub-scan signal and the emission control signal are in a high level;
 - a fifth period in which the emission control signal is in a high level, the second scan signal is in a high level, the first scan signal is in a high level, and the first sub-scan signal is in a low level; and
 - a sixth period in which the first scan signal and the second scan signal are in a high level and the first sub-scan signal and the emission control signal are in a low level.
10. The pixel as claimed in claim 6, wherein pixel driving periods comprise:
- a first period in which the second emission control signal and the first scan signal are in a high level and the first emission control signal is in a low level;
 - a second period in which the second emission control signal and the first emission control signal are in a low level and the first scan signal is in a high level;
 - a third period in which the first emission control signal and the first scan signal are in a high level and the second emission control signal is in a low level;
 - a fourth period in which the first emission control signal is in a high level and the second emission control signal and the first scan signal is in a low level;
 - a fifth period in which the first emission control signal and the first scan signal are in a high level and the second emission control signal is in a low level;
 - a sixth period in which the first emission control signal, the second emission control signal, and the first scan signal are in a high level; and
 - a seventh period in which the first emission control signal is in a low level and the second emission control signal and the first scan signal are in a high level.
11. The pixel as claimed in claim 9, wherein the length of the fourth period varies.
12. The pixel as claimed in claim 10, wherein the length of the fourth period varies.
13. An organic light emitting display, comprising:
- a pixel unit including a plurality of pixels;
 - a data driver for supplying data signals to the pixels;
 - a power source supply unit for supplying a first pixel power source, a second pixel power source, a first compensation power source, and a second compensation power source to the pixels; and
 - a scan driver for selectively supplying the data signals, the first pixel power source, the second pixel power source, the first compensation power source, and the second compensation power source to the pixels so that the pixel current corresponding to the data signals flows to the pixels,
- wherein each of the pixels comprise:
- an organic light emitting diode (OLED) receiving pixel current flowing from the first pixel power source to the second pixel power source to emit light;
 - a first transistor, comprising:
 - a gate coupled to a first node;
 - a first electrode coupled to the first pixel power source; and
 - a second electrode coupled to a second node, wherein the pixel current flows from the first electrode to the second electrode according to a voltage of the gate;
 - a second transistor for selectively supplying a data signal to a third node;
 - a third transistor for selectively and electrically coupling the gate of the first transistor to the second electrode of the first transistor;
 - a fourth transistor for selectively supplying a voltage of a second compensation power source to a fourth node;
 - a fifth transistor for selectively supplying a voltage of a first compensation power source to the third node;
 - a sixth transistor for selectively supplying the pixel current to the OLED;
 - a first capacitor positioned between the second node and the fourth node; and
 - a second capacitor positioned between the third node and the fourth node.
14. The organic light emitting display as claimed in claim 13, wherein the voltage of the first compensation power source is a voltage of the data signal for displaying black.
15. The organic light emitting display as claimed in claim 13, wherein the voltage of the first compensation power source is substantially equal to the voltage of the first pixel power source.
16. The organic light emitting display as claimed in claim 13, wherein the voltage of the second compensation power source is substantially equal to the voltage of the second pixel power source.
17. The organic light emitting display as claimed in claim 13,
- wherein turning on and off the second transistor and the fourth transistor is determined by a first scan signal, wherein turning on and off the third transistor is determined by a second scan signal, wherein turning on and off the fifth transistor is determined by a first sub-scan signal, and wherein turning on and off of the sixth transistor is determined by an emission control signal.

- 18.** The organic light emitting display as claimed in claim **13**, wherein turning on and off the second transistor is determined by the first scan signal, wherein turning on and off the third transistor and the fourth transistor is determined by a second emission control signal, and wherein turning on and off the fifth transistor and the sixth transistor is determined by a first emission control signal.
- 19.** The organic light emitting display as claimed in claim **17**, wherein, after the first scan signal becomes a turn-on signal, the second scan signal becomes a turn-on signal and the emission control signal becomes a turn-off signal, and wherein, after the second scan signal becomes a turn-off signal, the first scan signal becomes a turn-off signal and the emission control signal becomes a turn-on signal.
- 20.** The organic light emitting display as claimed in claim **18**, wherein the first scan signal has a turn-on period in a period where the first emission control signal is turned off, and wherein the first emission control signal becomes a turn-off signal after the second emission control signal becomes a turn-on signal and becomes a turn-on signal after the second emission control signal becomes a turn-off signal.
- 21.** The organic light emitting display as claimed in claim **17**, wherein pixel driving periods comprise:
- a first period in which the first sub-scan signal and the emission control signal are in a low level and the first scan signal and the second scan signal are in a high level;
 - a second period in which the first scan signal and the emission control signal are in a low level and the first sub-scan signal and the second scan signal are in a high level;
 - a third period in which the first scan signal, the second scan signal, and the emission control signal are in a low level, and the first sub-scan signal is in a high level;
 - a fourth period in which the first scan signal and the second scan signal are in a low level and the first sub-scan signal and the emission control signal are in a high level;
 - a fifth period in which, the emission control signal is in a high level, the second scan signal is in a high level, the first scan signal is in a high level, and the first sub-scan signal is in a low level; and
 - a sixth period in which the first scan signal and the second scan signal are in a high level and the first sub-scan signal and the emission control signal are in a low level.
- 22.** The organic light emitting display as claimed in claim **18**, wherein pixel driving periods comprise:
- a first period in which the second emission control signal and the first scan signal are in a high level and the first emission control signal is in a low level;
 - a second period in which the second emission control signal and the first emission control signal are in a low level and the first scan signal is in a high level;
 - a third period in which the first emission control signal and the first scan signal are in a high level and the second emission control signal is in a low level;
 - a fourth period in which the first emission control signal is in a high level and the second emission control signal and the first scan signal is in a low level;
 - a fifth period in which the first emission control signal and the first scan signal are in a high level and the second emission control signal is in a low level;
 - a sixth period in which the first emission control signal, the second emission control signal, and the first scan signal are in a high level; and
 - a seventh period in which the first emission control signal is in a low level and the second emission control signal and the first scan signal are in a high level.
- 23.** The organic light emitting display as claimed in claim **20**, wherein the length of the fourth period varies.
- 24.** The organic light emitting display as claimed in claim **21**, wherein the length of the fourth period varies.

* * * * *

专利名称(译)	使用其的像素和有机发光显示器		
公开(公告)号	US20110090202A1	公开(公告)日	2011-04-21
申请号	US12/852344	申请日	2010-08-06
[标]申请(专利权)人(译)	三星显示有限公司		
申请(专利权)人(译)	三星移动显示器有限公司.		
当前申请(专利权)人(译)	三星DISPLAY CO. , LTD.		
[标]发明人	HAN SAM IL		
发明人	HAN, SAM-IL		
IPC分类号	G09G3/30 G09G5/00		
CPC分类号	G09G3/32 G09G3/3233 G09G2300/0861 G09G2300/0819 G09G2300/0842 G09G2300/0814		
优先权	1020090099213 2009-10-19 KR		
其他公开文献	US9013374		
外部链接	Espacenet USPTO		

摘要(译)

公开了一种用于有机发光二极管显示器的像素电路。像素配置为提供快速响应时间和与数据转换耦合的良好隔离。

